

DOR-O-MATIC®

Installation Instructions

Series 2090 Rim Panic Device

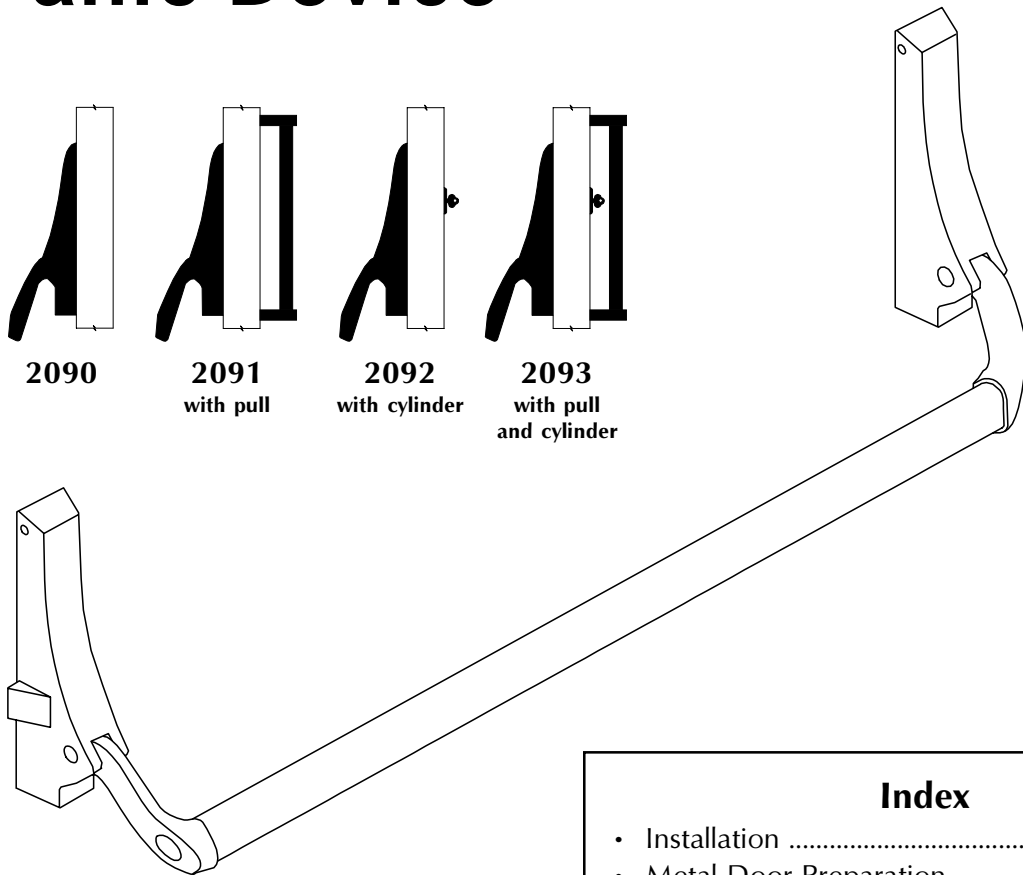

2090

2091
with pull

2092
with cylinder

2093
with pull
and cylinder

Index

- Installation 2
- Metal Door Preparation 3
- Wood Door Preparation 3
- Series 2090 Parts List 4



NOTES

1. Handing of device cannot be changed.
2. Crossbar length equals the distance between the housing vertical center lines minus 1-3/4".

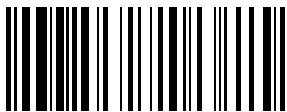

4270101872 (Revision 1)

Copyright © 2005 Ingersoll-Rand. All rights reserved.

IR Security & Safety
Proven Source. Proven Solutions.™

INSTALLATION

1. Check "Series 2090 Parts List" (see page 4).
2. Prepare door for device (see page 3).



NOTE

Dimensions on lock and lock screw holes will function with the following 5-pin tumbler rim cylinders: Corbin, Lockwood, Schlage, Welch, Yale. For other brands, refer to lock maker's template.

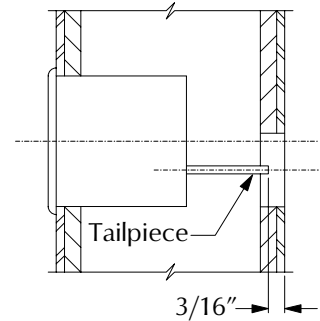

Figure 1

3. **Aluminum and hollow metal doors:** Install housing mounting studs in door.

Wood door: Install assembly plates in door cutouts.

4. Install cylinder if used. If required, cut tailpiece (Figure 1). Cylinder screw heads must be flush with door surface.
5. If cylinder is used, set pinion cam on back of active housing for hold-back (HB) or night latch (NL) operation (Figure 2).

Hold-back (HB): Turning key one complete rotation retracts latch bolt. If key is removed in this position, latch bolt stays retracted. Returning key to original position before removing allows latch bolt to extend.

To set for hold-back: Turn pinion cam until latch bolt starts to retract, then turn pinion cam the other way as far as it will go. Leave pinion cam in this position.

Night latch (NL): Turning key as far as it will go retracts latch bolt. Key must be returned to original position to be removed, leaving the door locked.

To set for night latch: Turn pinion cam until latch bolt starts to retract. Leave pinion cam in this position.

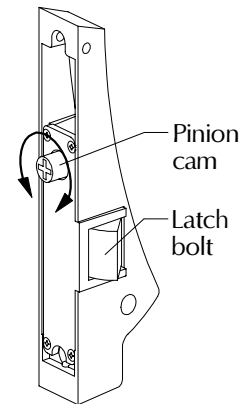

Figure 2

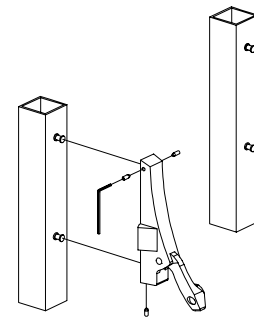

Figure 3

6. Install active housing over mounting studs and tighten set screws (Figure 3).
7. Check lever arm operation to ensure that all parts move freely. If cylinder is used, check that the cylinder functions correctly for either hold-back or night latch.
8. Install crossbar and inactive housing (Figure 4). Tighten inactive housing set screws and fasten crossbar with Taptite screws (item No. 16 in "Series 2090 Parts List," page 4).
9. Prepare frame for strike and install strike (see bottom of page 4).

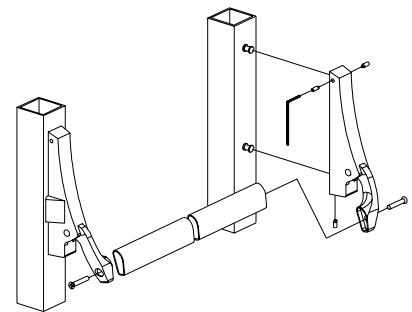
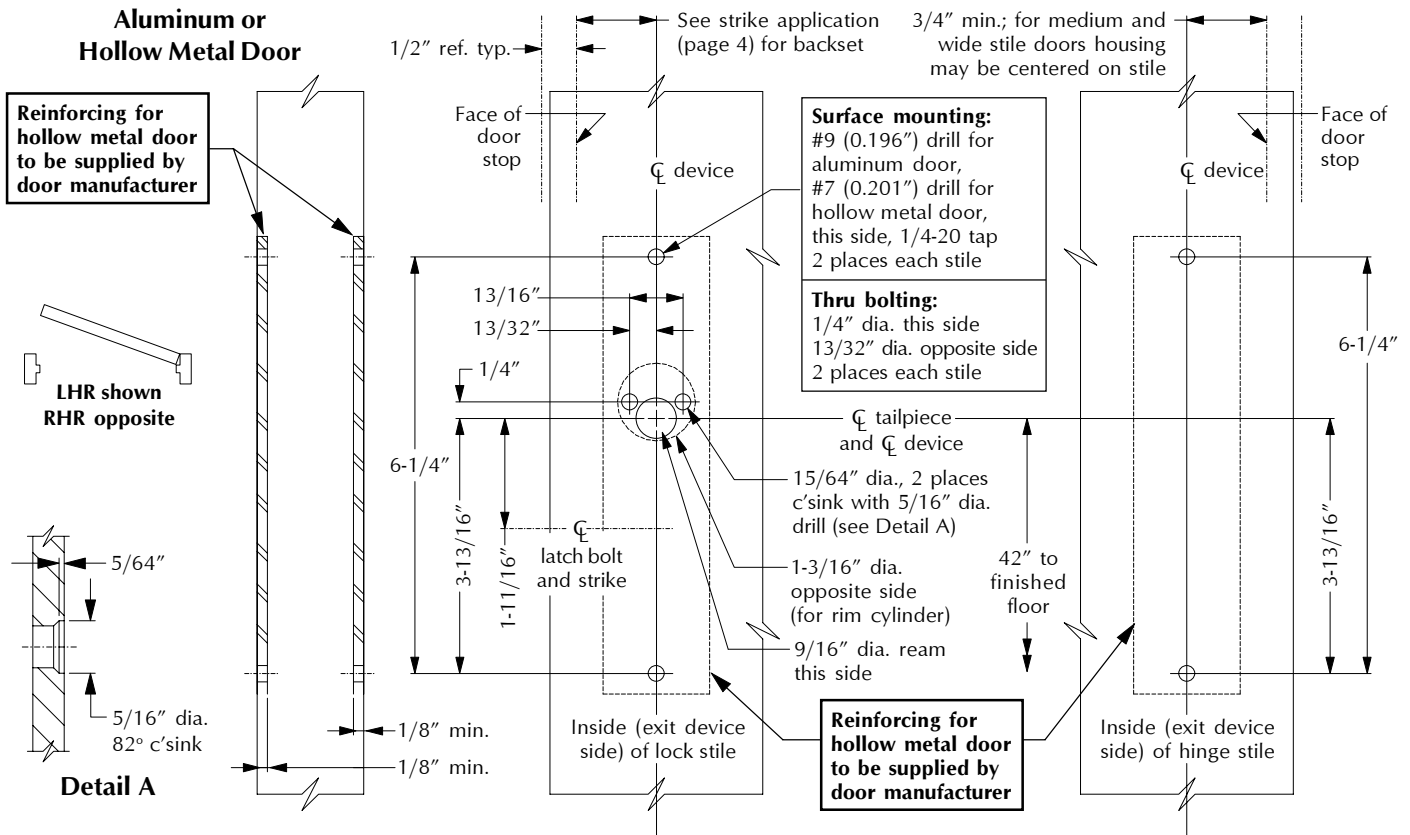
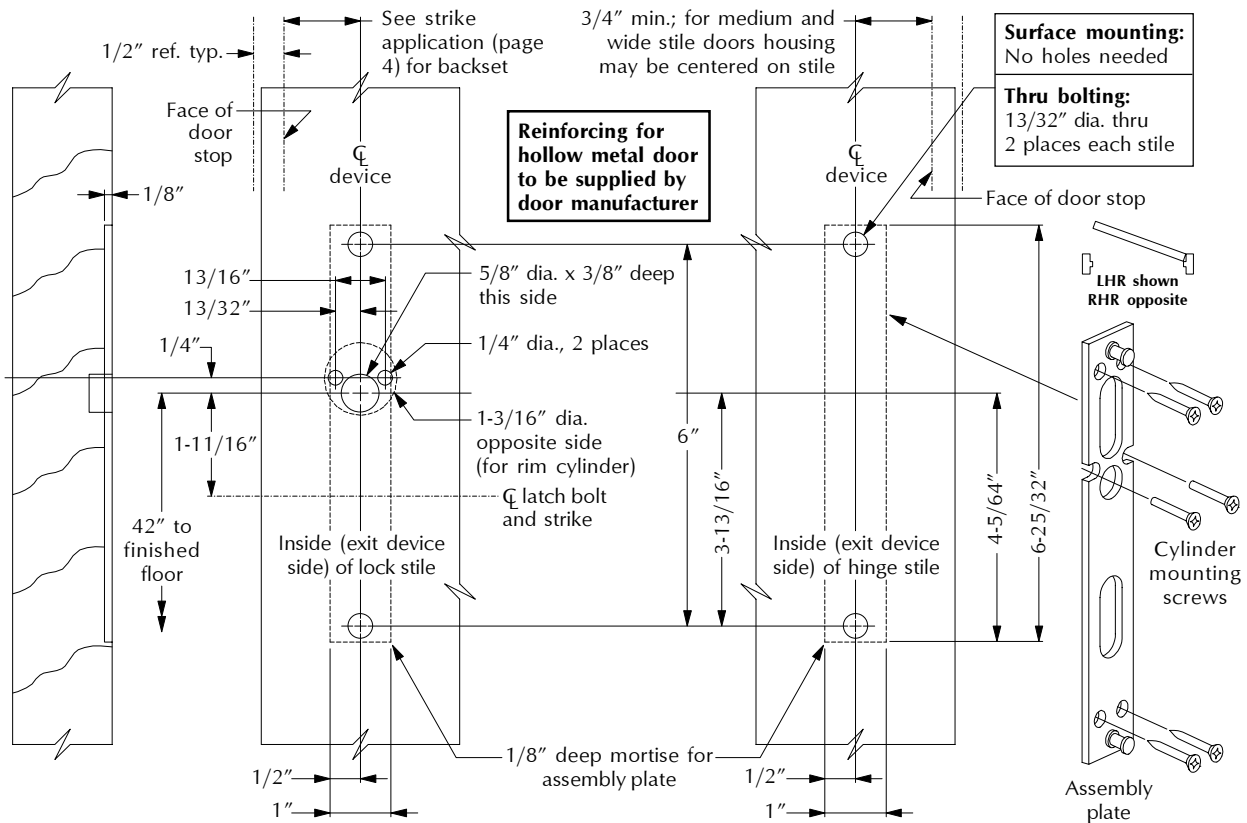

Figure 4

METAL DOOR PREPARATION



WOOD DOOR PREPARATION



SERIES 2090 PARTS LIST

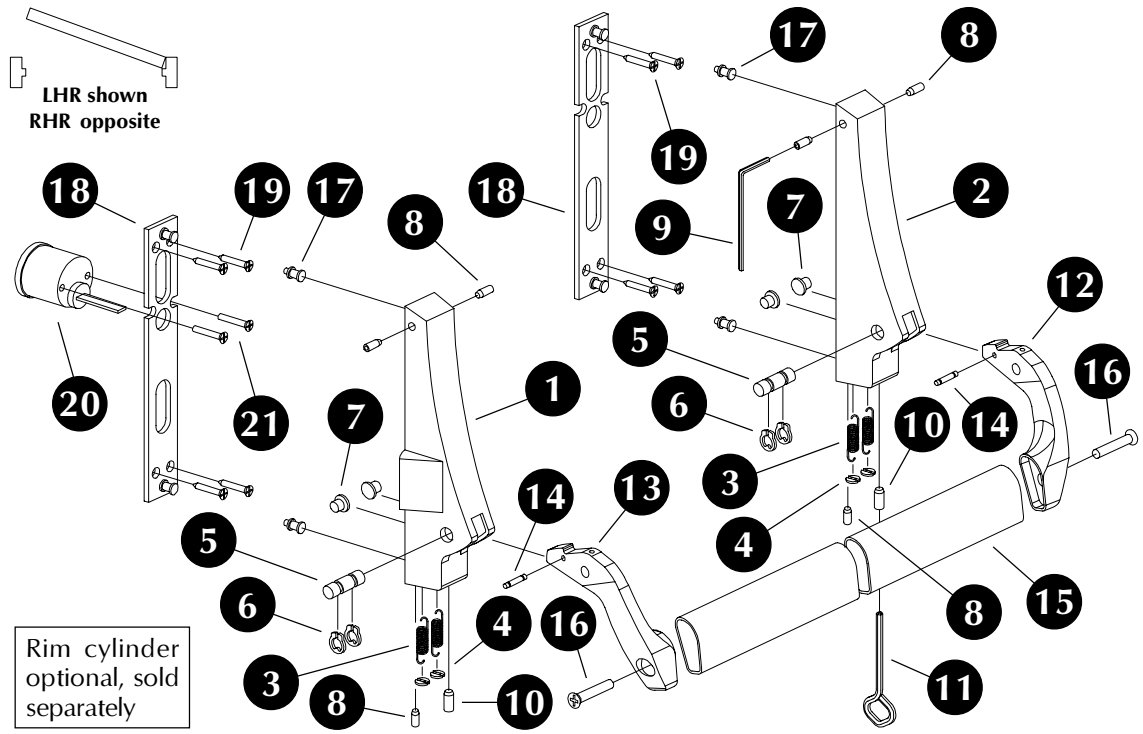

Item	Qty.	Description
1	1	Housing, active (RHR or LHR)
2	1	Housing, inactive (RHR or LHR)
3	4	Tension spring
4	2	Spring retainer
5	2	Axle pin
6	4	Retaining ring
7	4	Axle bushing

Item	Qty.	Description
8	6	1/4-20 x 3/8" socket head set screw
9	1	1/8" Allen wrench
10	2	7/16-14 x 3/4" socket head set screw
11	1	Dogging key
12	1	Lever arm, LH
13	1	Lever arm, RH
14	2	Spring pin

Item	Qty.	Description
15	1	Crossbar
16	2	1/4-20 x 1" Taptite
17	4	Housing mounting stud (metal doors)
18	2	Assembly plate (for wood doors)
10	8	#10 x 1" FPHSMS (for wood doors)
20	1	Rim cylinder
21	2	Rim cylinder screws

SD36 Strike (standard)

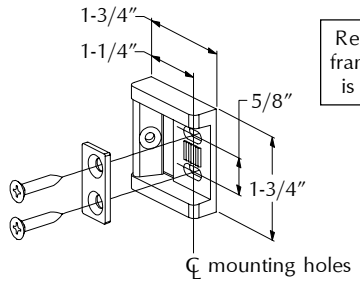

SD35 Strike (optional)

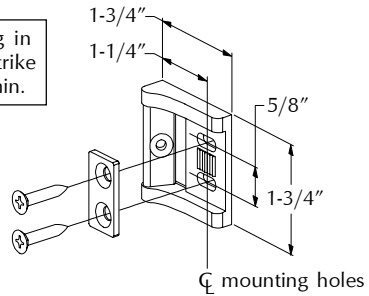

Double Doors with STK45 Strike

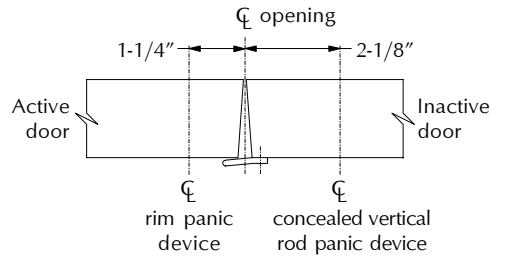

Surface Mounted Strike

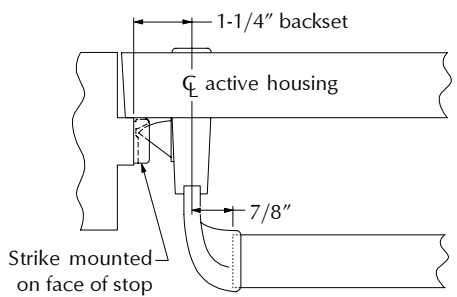

Mortised Strike

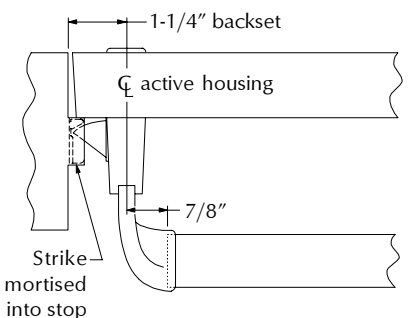

Double Doors with RM70 Mullion

